

(No Model.)

H. E. PROCUNIER.

APPARATUS FOR EDGING METAL RIBBONS OR STRIPS.

No. 493,294.

Patented Mar. 14, 1893.

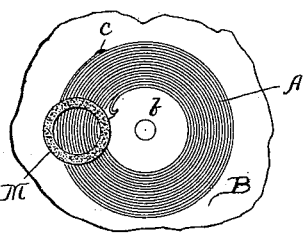
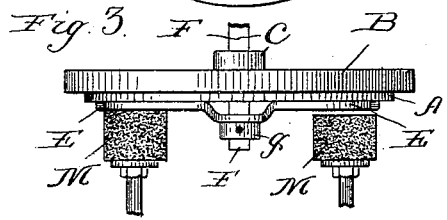
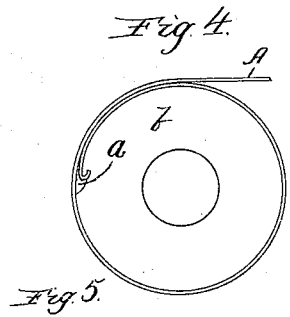
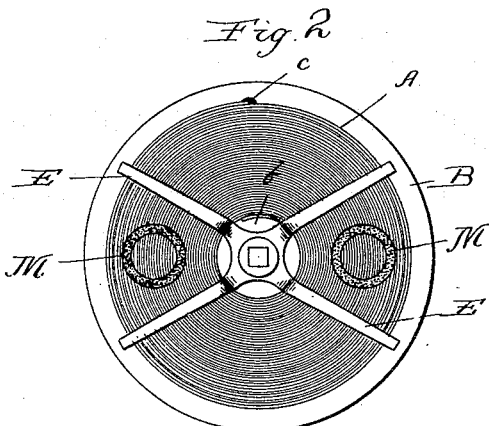
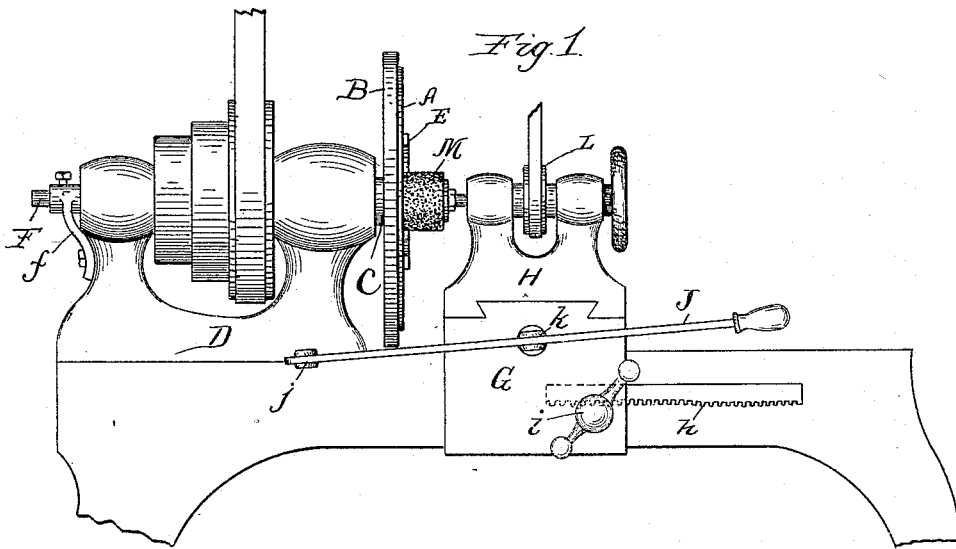

Witnesses:

Sew. C. Curtis
S. W. Munday

Inventor:

Henry E. Procunier

By Munday Curtis & Adcock
His Attorneys.

UNITED STATES PATENT OFFICE.

HENRY E. PROCUNIER, OF OAK PARK, ASSIGNOR TO THE AMERICAN SPRING COMPANY, OF CHICAGO, ILLINOIS.

APPARATUS FOR EDGING METAL RIBBONS OR STRIPS.

SPECIFICATION forming part of Letters Patent No. 493,294, dated March 14, 1893.

Application filed May 4, 1891. Serial No. 391,521. (No model.)

To all whom it may concern:

Be it known that I, HENRY E. PROCUNIER, a citizen of the Dominion of Canada, residing at Oak Park, in the county of Cook and State of Illinois, have invented a new and useful Improvement in Apparatus for Edging Metal Ribbons or Strips, of which the following is a specification.

This invention relates to improvements in apparatus for forming true and even edges upon ribbons or strips of metal, and for trimming such ribbons to a uniform width throughout their entire length.

It has been customary heretofore to grind and polish the edge of the ribbon or strip by means of emery and buff wheels acting upon the ribbon or strip while it is being drawn with a continuous motion past such wheels. Sometimes, instead of using wheels, scrapers or files or other devices which will rub the edge while the strip is passing, have been employed. Sometimes also the ribbon or strip has been drawn through plates or dies adapted to give it the form of edge and the width desired. Finding that good and rapid work cannot be done by any of these machines, especially where the material operated upon is hardened steel, such for instance as those used in watch springs and surveyors' lines, I have devised my present invention, the nature whereof will be fully understood from the description which I give below, when considered in connection with the accompanying drawings.

In the drawings Figure 1 is an elevation of a form of the apparatus. Fig. 2 is an elevation of a coiled ribbon and the devices for holding it in the apparatus, and Fig. 3 is an edge view of the same parts. Fig. 4 shows the manner of winding the strip preparatory to its being operated upon. Fig. 5 is a partial view similar to Fig. 2 showing a smaller coil being operated upon.

In practicing my invention I take the metal strip or ribbon indicated in the drawings at A and wind it tightly around the hub *b* which may be integral with the face plate B or separate therefrom. The end of the strip is first secured to the hub by bending it into the recess *a* formed in the hub and then winding proceeds until the entire strip is wound

up, the coils lying one upon the other and the coiling being as close as may be. The final end of the strip may be soldered to prevent unwinding, as shown at *c* or secured in any other suitable way. The coils should be placed and pressed against the face plate B at all points, so that they will be solid against said plate. The plate with the wound ribbon is now secured upon the arbor C of a lathe or similar machine, the head block of which is shown at D, and is rotated by such lathe. I prefer to further secure the coils by some device which will hold them against slipping off and also retain them in position notwithstanding the expansion caused by the heat generated by the grinding. The device which I employ for this purpose consists of the spider like device shown at E, the same embracing a suitable number of arms projecting from a central body. These arms bear against the exposed edges of the wound strip, and the spider is held in position by the spindle or rod F which is inserted through the hollow arbor of the machine and stationarily held in position therein by the bracket *f* attached to the head stock. The spider E may be locked upon the rod F by the washer and nut shown at *g*.

G is a compound slide mounted upon the bed of the machine and which may be adjusted thereon longitudinally of the bed by a pinion actuated from the handle *i*, the pinion not being indicated in the drawings and meshing with the rack *h*. Any other construction of adjusting devices may be used, and usually where the rack and pinion are employed, a screw adjustment will be found advisable to supplement them. Such supplemental adjusting devices are not shown as they are found in nearly all lathes. The grinding wheel carrier H is mounted upon slide G and may be adjusted or fed in planes parallel to the face plate B at right angles to the axial line of the machine by means of the hand lever J fulcrumed at *j* and suitably connected to the carrier at *k*. In this carrier H I mount one or more emery or buff wheels M, or one of each, and drive them by means of pulleys and belts as illustrated at L. Where the spider is used these wheels M are located between the branching arms of the spider, as clearly illustrated in the drawings. The

emery and buff wheels which I prefer to use are known as cup shape, though other descriptions may be employed, if desired. The face plate and wheels being set in motion, the operator moves the carrier H to bring the wheel M against the coil, and he also moves it back and forth, if that be necessary to carry the wheel M into contact with every part of the wound strip. It necessarily follows from this operation, whether the wheel be stationarily held against the coil or moved across the same in a straight line, that the edge of the entire strip will be so ground or smoothed off as to bring the edges of all the coils to the same plane. After this has been done to one side of the strip, it is taken off the face plate and replaced thereon with the ground edge next the plate, and the same operation is then repeated with the edge thus exposed. When this has been done, it will be found that the entire strip has been reduced to a uniform width.

If it is desired, the wheels M may both be emery wheels, and one may be finer than the other, or one of them may be a buff wheel and adapted to impart a fine polish to the edge, and only one wheel may operate upon the strip at a time. It will be obvious that a ribbon treated in the manner I have described will thereby be given a square polished edge as well as a uniform gage.

When positioned in the lathe in the manner described, the grinding brings the side of the coil operated upon to a uniform plane, and when the coil is reversed and its other side subjected to the same operation, the two sides will be exactly parallel with each other, so that a uniformity of width throughout all parts of the coiled strip is sure to result.

As a rule I prefer not to operate upon coils so large as to require the cross movement of the grinder, the preferred method of operating being shown in Fig. 5 where the grinder or buffer is of sufficient diameter to cover all the coils.

It will be noticed that the grinding is performed in my machine by the end of the emery or other grinding wheel, the wheel being positioned and presented endwise to the coiled strip. This manner of grinding not only enables me to do much better work than can be

done where the grinding is performed by the face or periphery of the wheel, but the wheel itself is by my manner of use automatically kept at all times true, and of course this results in an improved quality of work.

I claim—

1. The apparatus for edging metal strips consisting of the hub *b*, plane surfaced face plate B, and the machine arbor C, in combination with a rotating emery or buff wheel and means for driving such wheel, substantially as set forth.

2. The apparatus for edging metal strips consisting of the hub *b*, face plate B, the machine arbor C, and the spider E and its support, in combination with a rotating emery or buff wheel and means for driving such wheel, substantially as set forth.

3. As a means for supporting the coiled strip while its edge is being ground, the hub *b*, face plate B, the spindle carrying said hub and plate and a retaining device adapted to hold the coiled strip in place, such as E, and suitable supports for such retaining device, all combined and operating substantially as set forth.

4. In combination with means embracing a face plate for supporting and rotating a coil of metal ribbon, and means for grinding or polishing the side of the coil, a retaining device for holding the coils in position against said face plate, substantially as set forth.

5. In combination with means for supporting and rotating a coiled metal ribbon or strip, a stationary device adapted to retain the coils of the strip in position while being ground, substantially as set forth.

6. In combination with means for supporting and rotating a coiled metal ribbon or strip, a grinding wheel presented endwise for action upon the ribbon, substantially as set forth.

7. In combination with means for supporting and rotating a coiled metal ribbon or strip, a rotating grinding wheel movable across the side of the coil, substantially as set forth.

HENRY E. PROCUNIER.

Witnesses:

EMMA HACK,
H. M. MUNDAY.